

FOSSIL CORAL ARC WALL LIGHT WITH BRASS OR COPPER ARM

INSTALLATION INSTRUCTIONS
FOR DOME + CONE IN SML. MED. LG. XLG



12V+ G4 GLOBE
(2.5W LED 270° LAMP INPUT VOLTAGE 12VDC)
MUST BE INSTALLED BY A LICENSED ELECTRICIAN

MAROVO
ISLAND TRADERS

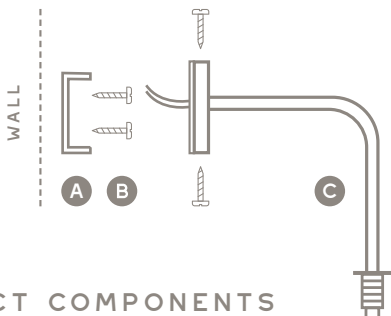

PRODUCT COMPONENTS

- A. 1X BRASS WALL PLATE
- B. 4X SCREWS
- C. 1X BRASS WALL ARM WITH SILICONE SEAL (WITH 12V WIRING AND G4 LAMP HOLDER)
- D. 1X G4 GLOBE (12V) WARM WHITE 2.5 WATTS
- E. 1X FOSSIL CORAL LIGHT SHADE
- F. 1X WALL SECURING NUT
- G. 1X GLOBE DIFFUSER (THREADED)

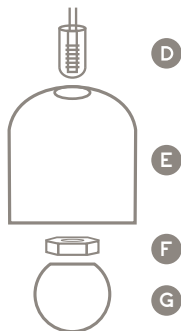

INSTALLATION

1. ATTACH WALL BRACKET TO WALL USING 2 SCREWS
2. CONNECT WIRES ON THE BRASS WALL ARM TO A 12V DRIVER
3. SCREW BRASS WALL ROSE/ARM ONTO WALL BRACKET USING 2 SCREWS
4. SLIDE G4 GLOBE ONTO LAMP HOLDER
5. WIND LIGHT SHADE OVER THREADED ARM UNTIL SECURE. DO NOT FORCE OR OVER TIGHTEN
6. WIND SAFETY NUT ONTO THREADED ARM
7. WIND LIGHT DIFFUSER ONTO THREADED ARM

NATURAL VARIATION IN CHARACTER

All Fossil Coral products are hand-crafted with unique variations in character and detail. The expressions of sacred geometry are never the same and the natural imperfections evoke the timeless rare antiquity.

Fossil Coral is a type of natural stone that forms over millions of years from the gradual accumulation of ancient coral and other organic materials. These variations in colour, pattern, fracture lines and texture and are not considered to be defects but rather celebrations of the beauty and uniqueness of each piece.

We take great care in selecting high-quality Fossil Coral for our products, and we strive to ensure that each item we produce meets our high standards of quality and craftsmanship. However, because of the natural variations in the stone, no two pieces will be exactly alike.

PRODUCT CARE

Fossil Coral light shades may be gently dusted or removed from electrical components and hand washed in warm soapy water.

HELLO@MAROVOISLANDTRADERS.COM

MAROVOISLANDTRADERS.COM

WARRANTY

Thank you for purchasing our hand-crafted Fossil Coral lights. We take great pride in the quality of our products and are confident that you will enjoy your new purchase for years to come. Our Fossil Coral lights are covered by a limited warranty for 12 months from the date of purchase.

The warranty covers faulty defects in materials and workmanship under normal use. Please note, that the warranty excludes light bulbs and does not cover damage caused by misuse, breakages or accidents. All Marovo Island Traders lights must be installed by a certified electrician.

If you believe that your Fossil Coral light has a defect covered by this warranty, please contact us to initiate a warranty claim including your proof of purchase. Upon receipt of your claim, we will review the information provided and may request additional information or photos of the product. If we determine that your Fossil Coral light is covered by the warranty, we will repair or replace the product at our discretion.

Please do not hesitate to contact us with any queries about your precious piece.

HELLO@MAROVOISLANDTRADERS.COM

MAROVOISLANDTRADERS.COM

WALL ARC SPECIFICATIONS

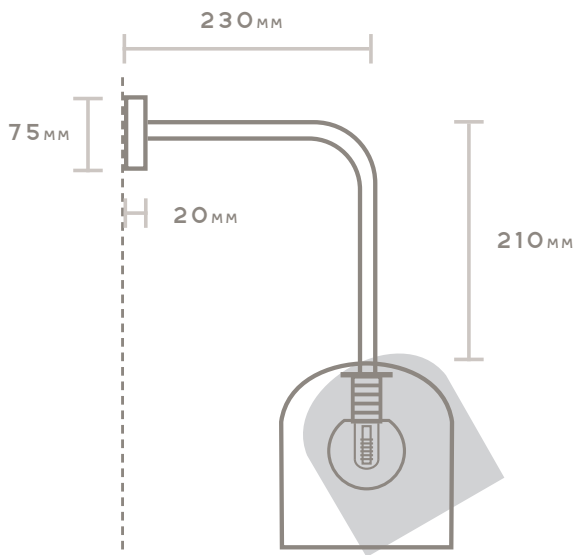

SHADE SIZES (MM):

DOME:

SML: 80D X 130H

MED: 130D X 140H

LG: 140D X 160H

XLG: 255D X 210H

CONE:

SML: 170D X 150H

MED: 185D X 180H

LG: 220D X 190H

XLG: 270D X 200H