

## FOSSIL CORAL MUSHROOM TABLE LAMP

---

INSTALLATION INSTRUCTIONS

FOSSIL CORAL SHADE + BRASS BASE

12V+ G4 LED GLOBE 2.5 WATTS

(2.5W LED 270° LAMP INPUT VOLTAGE 12VDC)

MAROVO  
ISLAND TRADERS

## PRODUCT COMPONENTS

- A. 1X LAMP STAND (BRASS BASE) WITH 12V WIRING + G4 LAMP HOLDER
- B. 1X G4 LED GLOBE (12V) WARM WHITE 2.5 WATTS
- C. 1X FOSSIL CORAL LIGHT SHADE
- D. 1X SECURING NUT
- E. 1X GLOBE DIFFUSER

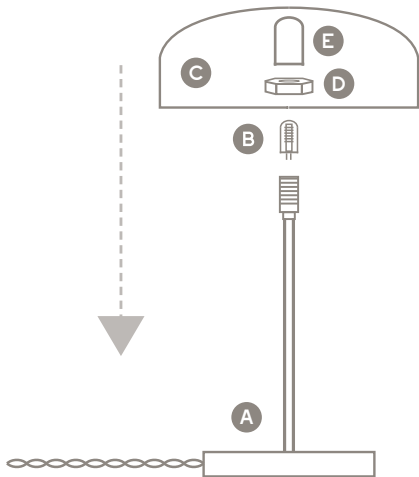

## INSTALLATION

1. PLACE LAMP STAND ON A STABLE EVEN SURFACE AND KEEP UNPLUGGED
2. PUSH GLOBE PINS INTO LAMP HOLDER
3. GENTLY PLACE FOSSIL CORAL LAMP SHADE ONTO LAMP STAND AND HOLD IN PLACE WHILE WINDING ON SECURING NUT UNTIL TIGHT
4. WIND LAMP DIFFUSER OVER THE LED GLOBE INSIDE THE LAMP SHADE
5. PLUG INTO WALL AND TURN ON

## NATURAL VARIATION IN CHARACTER

All Fossil Coral products are hand-crafted with unique variations in character and detail. The expressions of sacred geometry are never the same and the natural imperfections evoke the timeless rare antiquity.

Fossil Coral is a type of natural stone that forms over millions of years from the gradual accumulation of ancient coral and other organic materials. These variations in colour, pattern, fracture lines and texture and are not considered to be defects but rather celebrations of the beauty and uniqueness of each piece.

We take great care in selecting high-quality Fossil Coral for our products, and we strive to ensure that each item we produce meets our high standards of quality and craftsmanship. However, because of the natural variations in the stone, no two pieces will be exactly alike.

## PRODUCT CARE

Fossil Coral light shades may be gently dusted or removed from electrical components and hand washed in warm soapy water.

HELLO@MAROVOISLANDTRADERS.COM

MAROVOISLANDTRADERS.COM

## WARRANTY

Thank you for purchasing our hand-crafted Fossil Coral lights. We take great pride in the quality of our products and are confident that you will enjoy your new purchase for years to come. Our Fossil Coral lights are covered by a limited warranty for 12 months from the date of purchase.

The warranty covers faulty defects in materials and workmanship under normal use. Please note, that the warranty excludes light bulbs and does not cover damage caused by misuse, breakages or accidents. All Marovo Island Traders lights must be installed by a certified electrician.

If you believe that your Fossil Coral light has a defect covered by this warranty, please contact us to initiate a warranty claim including your proof of purchase. Upon receipt of your claim, we will review the information provided and may request additional information or photos of the product. If we determine that your Fossil Coral light is covered by the warranty, we will repair or replace the product at our discretion.

Please do not hesitate to contact us with any queries about your precious piece.

HELLO@MAROVOISLANDTRADERS.COM

MAROVOISLANDTRADERS.COM

# MUSHROOM TABLE LAMP SPECIFICATIONS

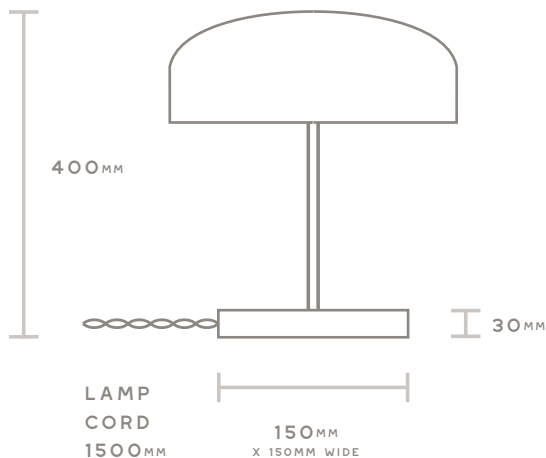

SHADE SIZE (MM):

---

DOME:

260D X 120H MM